



### CARATTERISTICHE ELETTRICHE / Electric characteristics

Tensione Nominale - Nominal Voltage	0/600 V <sub>ac</sub> - 50/60 Hz
Tensione di prova fase/fase - Phase to phase test voltage	2700 V <sub>dc</sub> (2 s)
Tensione di prova fase/terra - Phase to ground test voltage	3200 V <sub>dc</sub> (2 s)
Categoria climatica - Climatic class	-25 / +85 °C



UL1283

CSA C22.2

\* S.C.C.R. In according to UL508

FIN1900 FIN1900G	Rated current 40°C (50°C)	Σ Cx (μF) ± 5%	Cy1 (nF) ± 5%	Cy2 (nF) ± 5%	L1/L2 (mH) ± 10%	S.C.C.R. (kA)	Max Fuse (200kA RK5 TD)	Pot. diss. (W) Power loss (W)
.006.M	8 (6)	20	1000	100	1.5	5*	10A 600 Vac	8
.012.M	14 (12)	20	1000	100	1.5	5*	15A 600 Vac	10
.016.M	18 (16)	60	1000	100	1.4	5*	45A 600 Vac	12
.025.M	28 (25)	60	1000	100	1.3	5*	45A 600 Vac	15
.032.M	35 (32)	60	1000	100	1.2	5*	45A 600 Vac	23
.042.M	50 (42)	60	1000	100	1.1	5*	90A 600 Vac	32
.055.M	63 (55)	60	1000	100	1.1	5*	90A 600 Vac	37
.070.M	80 (70)	60	1000	100	1	10*	100A 600 Vac	52
.080.M	90 (80)	60	1000	100	1	10*	110A 600 Vac	60
.100.M	110 (100)	60	1000	100	0,9	10*	175A 600 Vac	92
.115.M	130 (115)	60	1000	100	0,8	10*	110A 600 Vac	101
.150.M	175 (150)	60	1000	100	0,7	10*	225A 600 Vac	115
.200.M	230 (200)	60	1000	100	0,6	-	300A**	120

### SCHEMA ELETTRICO FIN1900

FIN1900 Electric diagram

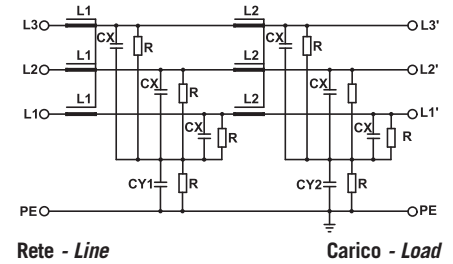

### SCHEMA ELETTRICO FIN1900G

FIN1900G Electric diagram

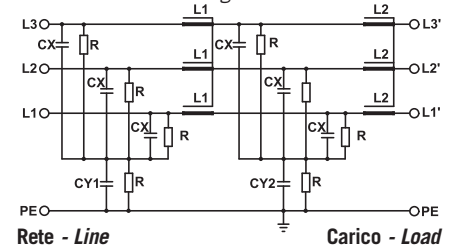

Corrente di fuga totale a 230 V fase verso terra a 50 Hz / 40°C

Total leakage current at 230 V phase to ground 50 Hz / 40°C

Nominale/Nominal <10mA

Condizione peggiore/Worst condition <80mA

\*\*Max 10kA should be provided by branch circuit fuse or a circuit breaker that clears the overcurrent fault within 3 cycles

### DIMENSIONI MECCANICHE (mm) / Mechanical dimensions (mm)

FIN1900 FIN1900G	A	B	V	V1	F	H	I	L	N	d	Peso Kg Weight Kg
.006.M/.012.M	140	50	19	15	6	226	200	7	28	M6	1,7
.016.M	177	60	19	15	6	267	237	8	34	M6	1,7
.025.M/.032.M	177	60	19	15	6	267	237	8	34	M6	2,3
.042.M	177	70	19	35	6	295	265	8	44	M6	3,4
.055.M	177	70	19	33	6	295	265	8	44	M6	3,5
.070.M/.080.M	205	80	28	38	8	390	340	12	53	M10	6
.100.M/.115.M	205	80	28	43	8	390	340	12	53	M10	7,1
.150.M/.200.M	220	105	28	50	8	420	370	12	78	M10	8

### DATI DI COLLEGAMENTO (mm²) / Terminal Block (mm²)

Morsetto Terminals	Cavo rigido Rigid Cable	Cavo flessibile Flexible Cable
K6	0.2 - 10	0.2 - 6
K6	0.2 - 10	0.2 - 6
K6	0.2 - 10	0.2 - 6
K10	0.5 - 16	0.5 - 10
K16	0.5 - 25	0.5 - 16
K25	6 - 35	10 - 25
K50	16 - 50	16 - 50
K95	25 - 95	35 - 95

### ATTENUAZIONE / Insertion loss

— Common Mode    - - - Differential Mode

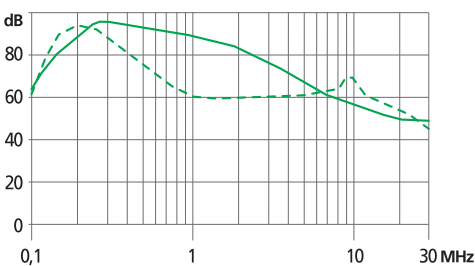

### CUSTODIA

Case

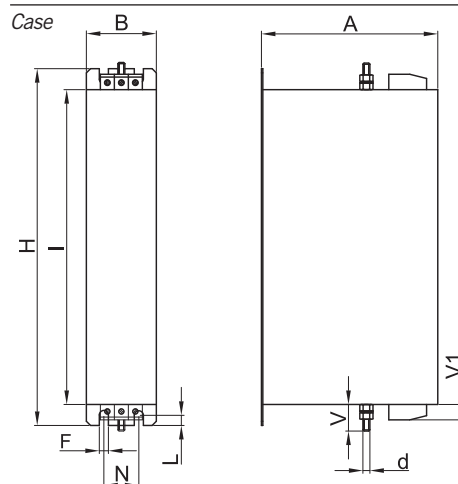

### ASSEMBLAGGIO

Assembling

